



## BATTERY RELIABILITY TEST SYSTEM MODEL 17010

The Chroma 17010 Battery Reliability Test System is a high precision, multi-functional charge/discharge testing platform designed for testing lithium-ion battery cells (LIB cells), electric double-layer capacitors (EDLCs), and lithium-ion capacitors (LICs). Engineered to address increasing reliability challenges across various applications-including electric vehicles, energy storage systems, and AI data centers-the platform supports a broad spectrum of testing stages from product development and performance evaluation to cycle life verification and product selection/classification.

Choose from two system architectures: the linear circuit series offers minimal output noise and exceptional measurement accuracy for development of small and medium-sized energy storage components; or the regenerative AC/DC bi-directional series for standard product life evaluation and testing of larger energy storage components and power batteries, all the while saving power and generating minimal heat.

The Chroma 17010 system is powered by the Battery Lab Expert (Battery LEX) software platform. With its multi-layered recipe architecture, users can quickly apply existing test profiles or create new ones, and establish a DUT database for convenient recipe sharing across different testing scenarios. The recipes support C-rate settings, OCV-SOC tables, Q%, and waveform simulations, covering a wide range of test applications as well as IEC, USABC, and GB/T standards. An integrated graphing tool allows users to quickly filter

data, generate charts, and export test results, complemented by template functionality for easy test report generation.

Chroma 17010 also includes built-in IEC 62813 test procedures for LICs. These include capacitance, DC internal resistance (DCIR), and cycle durability tests, enabling stable and efficient verification of LIC product quality.

The Chroma 17010 system supports integration with high-accuracy data loggers capable of measuring the DUT's temperature, voltage, and pressure in real time. These measurements can then serve as dynamic cut-off and protection conditions. The system is also compatible with environmental chambers from various manufacturers, allowing users to issue chamber control commands through test steps. Built-in chamber synchronization and secondary adjustment functionality further enhance user convenience.

The Chroma 17010 prioritizes 3 safety protection with a robust, software/hardware detection, equipment abnormality monitoring, and optional independent relay hardware detection, guaranteeing protection for both user and equipment throughout the testing process. It provides a comprehensive testing solution for lithium-ion battery degradation analysis tests, such as DVA, EIS, and DCIR.

## MODEL 17010

### KEY FEATURES

- High accuracy output and measurement up to  $\pm 0.01\%$  of F.S.
- High precision output and measurement up to  $\pm 0.001\%$  of F.S.
- High measure resolution up to 24 bits
- Fast current response up to  $<100\mu\text{s}$
- High sampling rate (10ms)
- High single point transient sampling rate (1ms)
- Integrating up to 96 channels
- Channel parallel output up to 1200A
- High-efficiency charge and discharge with low heating
- Energy recycling during discharge (AC/DC bi-directional regenerative series)
- Ripple emulation from 100Hz-20kHz, 75App
- Waveform simulation (current/power modes)
- One-stop EIS measurement solution
- High precision DVA/ICA solution
- IEC62813/IEC 623291 LIC/EDLC test solutions
- Multi-level safety protections
- Integrable data logger and chamber
- Compliant to IEC and GB/T battery standards

### APPLICATIONS

- AI computing platforms
- Electric vehicles
- Energy storage systems
- Quality inspection agencies
- Academic research

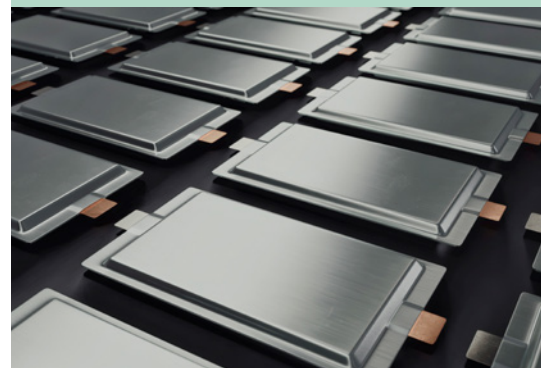

**Chroma**  
Advancing Excellence



## Feature Highlights-Ultra High Precision Charge/Discharge Tester 17208M-5-12C

The Chroma 17208M-5-12C is an ultra-high precision programmable charge/discharge tester specifically designed for precision measurement applications such as Coulombic Efficiency (CE) analysis, Incremental Capacity Analysis (ICA), and Differential Voltage Analysis (DVA). Applications like these call for instruments capable of measuring battery voltage and capacity for an extended period with high levels of stability, precision and accuracy, thereby obtaining high-quality test data without any need for postprocessing. The Chroma 17208M-5-12C goes above and beyond by offering four current ranges (12A, 4A, 0.4A, 40mA) and a 0-5V voltage measurement range for charge/discharge. To ensure optimal measurement quality, each channel is equipped with shielded wiring to isolate the equipment from noise.



### Best-in-class Stability, Precision, and Accuracy

Through meticulous structural and circuit design, the 17208M-5-12C effectively mitigates the impact of waste heat on its high-precision circuits and components, improving measurement stability during longer tests. With a measurement accuracy of up to  $\pm 0.01\%$  of F.S. (Full Scale) and precision of up to  $\pm 0.001\%$  of F.S., this tester reliably delivers consistent and repeatable test results.

- $\pm 0.01\%$  of F.S. measurement accuracy
- $\pm 0.001\%$  of F.S. measurement precision

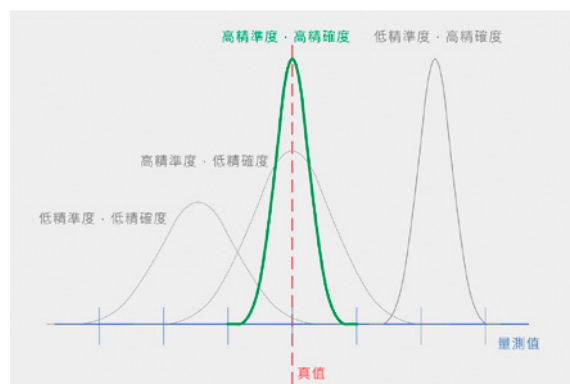

### High Resolution, Low Output Noise

The 17208M-5-12C employs a 24-bit ADC to enhance measurement resolution, providing highly granular test data that accurately reflects the DUT's actual electrical signal.

- Voltage measurement resolution: up to  $1\mu\text{V}$
- Current measurement resolution: up to  $0.01\mu\text{A}$

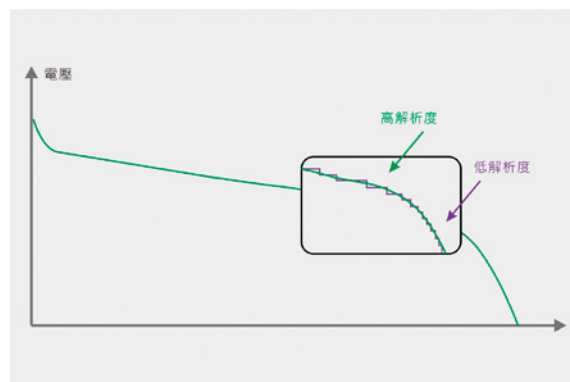

### Simplified DVA Test Data Processing

Differential Voltage Analysis (DVA) is commonly used to assess battery aging. However, poor measurement accuracy and precision can make it difficult to identify characteristic peaks, often requiring extensive resources to run smoothing algorithms and risking curve distortion. The 17208M-5-12C delivers stable full-range current output throughout the test. This ensures accuracy and minimizes noise from measurement fluctuations, resulting in DVA curves with clearly identifiable characteristic peaks.

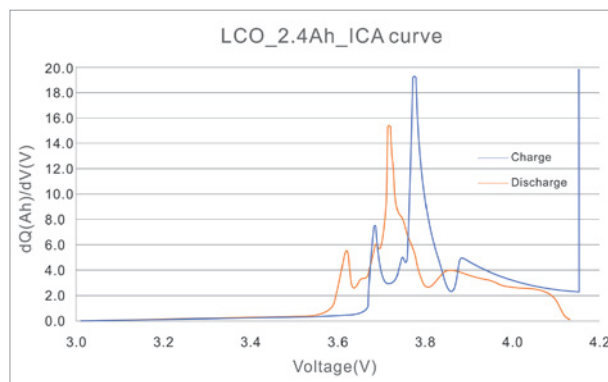
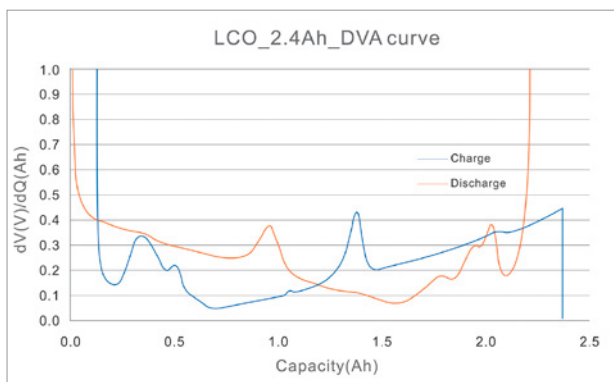

## Feature Highlights-17010 Series

### Multiple Current Range Design

#### ■ Quick switching of current ranges:

The Chroma 17010 series enables switching between multiple current output and measurement ranges to accommodate test plans with both high and low currents. At the start of each test step, the system detects the output current and then quickly switches to the appropriate current range automatically. This boosts the test's accuracy as well as its resolution, yielding quality test data you can trust.

#### ■ Automatic range switching under constant voltage (CV) mode:

The linear circuit models of the Chroma 17010 family support automatic switching between current ranges during testing in CV mode while maintaining uninterrupted output. This is ideal for applications like float charging and potential regulation, which require long-term and highly stable testing at very low currents.

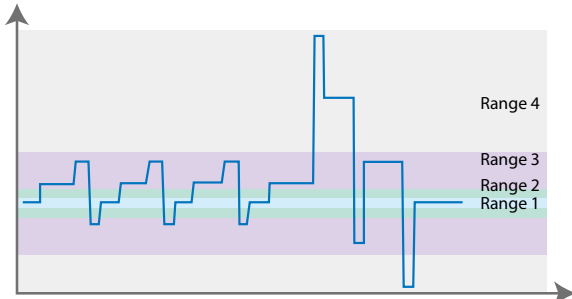

DST Application Test & Current Range  
(Using 17216M-6-12 model range)

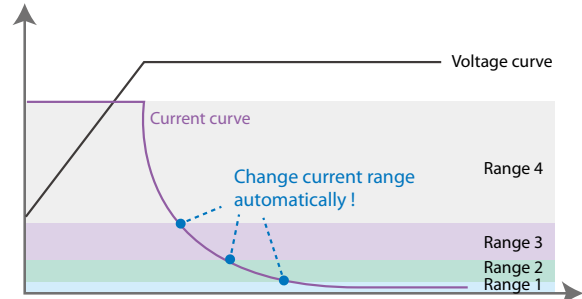

CV Test Current Switching

### High Stability Long-term Output

The Chroma 17010 is engineered for low output noise and superb measurement accuracy. Capable of converting test current and voltage data into highly accurate and distinct characteristic peaks, the 17010 enables you to investigate the aging mechanisms of your Li-ion batteries with unprecedented efficiency.

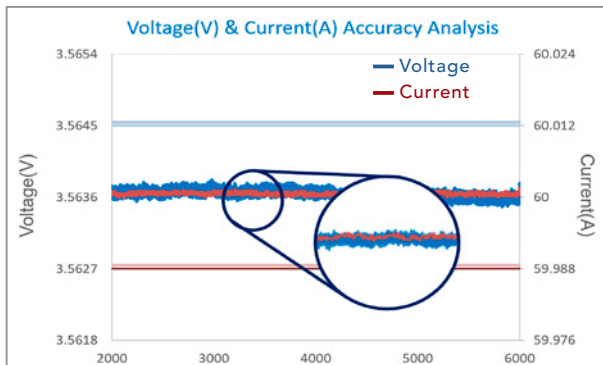

Actual Voltage/Current Measurement Accuracy

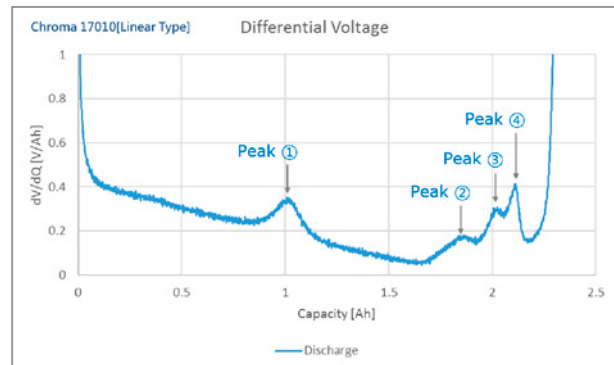

Differential Voltage Analysis Curve

### High-speed Sampling Technology

Conventional battery cyclers typically record key data at report sampling speeds, which produces significant cumulative error over time. The Chroma 17010 addresses this by utilizing high-speed voltage and current sampling with double-integration computing. This enables the system to accurately capture transient changes during testing without loss, resulting in highly reliable capacity calculations.

- Hardware internal voltage/current sampling rate: 1ms
- Report single point transient sampling rate: 1ms
- Report sampling rate: 10ms

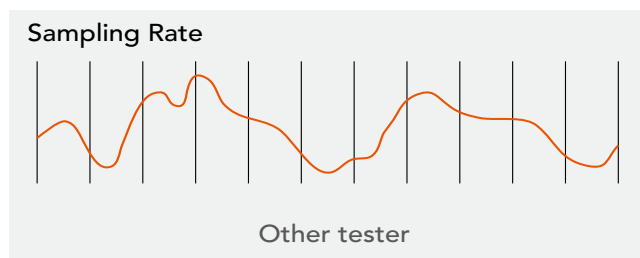

General Testers Charging/Discharging Sampling Rate

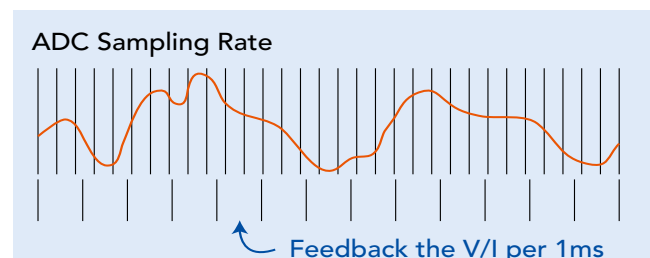

Chroma 17010 Charging/Discharging Sampling Rate

## Super Mode: 120% Charge/Discharge Output

The regenerative models in the 17010 family offer wide-ranging power and current coverage with their Super Charge/Discharge Output functionality. Super Mode allows you to easily configure and run up to 30 seconds of 120% current or power directly within your test steps, ideal for an array of high-current pulse test applications.

- 17212M-6-100S: 120% CC and CP charge/discharge output

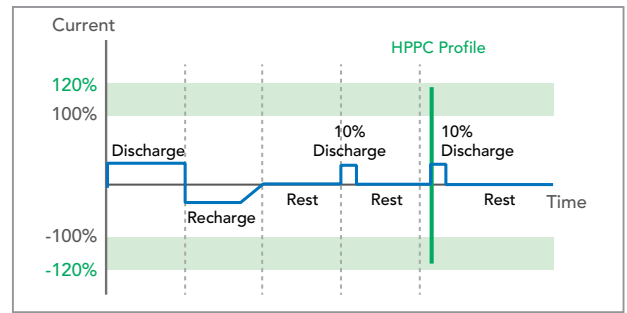

Hybrid Pulse Power Characteristic (HPPC)

## Fast Current Response (<1ms) for Optimal Realism

Besides Super Mode, the regenerative models also boast a current ramp-up time of less than 1ms. This enables more accurate simulation of the battery's instantaneous peak currents during on-road charging and discharging, meeting test data requirements for standards such as NEDC, FUDS, and DST.

- 17212M-6-100S: 10% to 90% in < 1ms

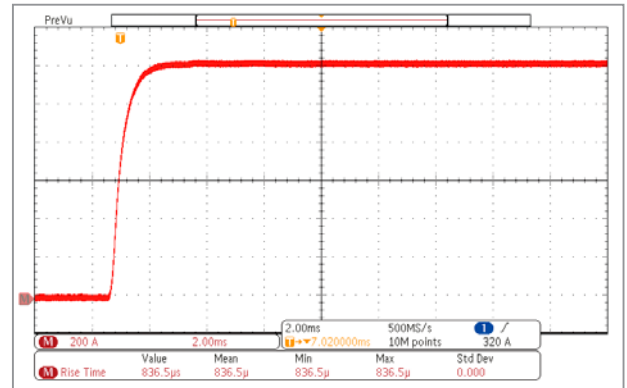

0-1200A Current Rise Time: <1ms

## Three Voltage Ranges

The Chroma 17216M-10-6 model offers three voltage ranges selectable via software, offering extra versatility for various product development applications.

- 0V to 5V: Half-cell, full-cell, EDLC
- 0V to 10V: Series batteries, EDLC
- -5V to 5V: Symmetric batteries

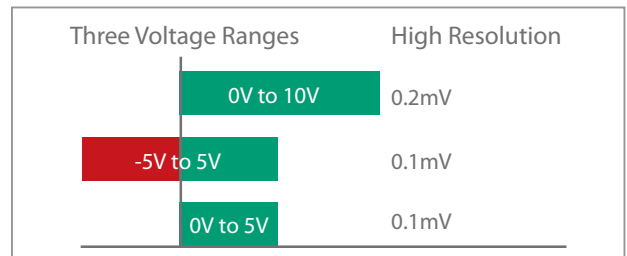

## Dynamic Waveform Loading

The Chroma 17010 goes beyond basic battery cycling by enabling you to preload dynamic charge/discharge waveforms. Evaluate your batteries' degradation modes and cycle life with enhanced realism by using dynamic current or power waveforms that closely mimic on-road charge/discharge conditions such as acceleration, deceleration, and uphill or downhill driving.

- Supports dynamic and fixed time modes (min. output interval 10ms)
- Dynamic preloading of up to 6,400,000 data points per system

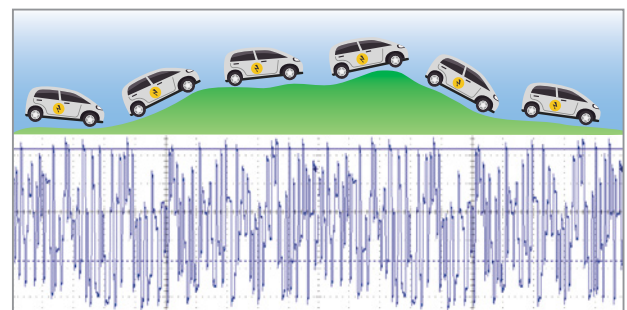

Dynamic Waveform Simulation

## Energy Recovery Architecture

The high-current models in the 17010 lineup feature high-precision, high-efficiency, and power-optimized energy recovery architecture, purposely designed to minimize waste heat generation during discharge and empower sustainable approaches to battery test.

- DC: Automatically prioritizes transferring discharged energy to charging channels with >80% recovery efficiency.
- AC: Excess energy is recovered back to the AC mains with >60% recovery efficiency.
- Current is fed back to the grid with <5% total harmonic distortion (THD).

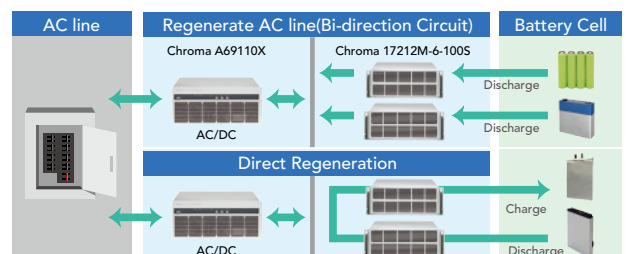

Energy Recycling Architecture

## Ripple Output

Chroma's ripple current test solution involves superimposing an AC current with a frequency between 100Hz and 20kHz onto the 17010 system (model 17212M-6-100S). This allows you to simulate the behavior of an electric vehicle (EV) inverter or the heating effect of AC current delivered from a charging station (EVSE) to the battery.

- Ripple frequency from 100Hz to 20kHz, amplitude up to 75App, and up to 150App in parallel (customizable)
- Independent AC and DC circuits, minimizing impact on DC charging and discharge cut-off judgment
- Ripple current superimposition in various CC, CV, and CP charging and discharging modes

## Parallel Current Output

The entire Chroma 17010 series supports dynamic parallel functionality, allowing idle continuous channels to be paralleled for higher current output. This feature not only enhances testing versatility but also accommodates a wider variety of test applications.

## Data Protection & Recovery Function

Experience peace of mind with Chroma 17010's robust data protection and recovery functionality. Enabled by an optional UPS (uninterruptible power system), this feature enables the system to temporarily store test data in the IPC database during power failures. After the power issues are resolved, the 17010 automatically retrieves the data state and resumes testing from the point of interruption, ensuring seamless data continuity.

## System Integration and Protection

The Chroma 17010 supports integration with environmental chambers of various well-known brands as well as multifunctional data loggers. With the Battery LEx software, you can set parameters and monitor data simultaneously. Test data is automatically compiled into test reports, all in all providing a fully comprehensive test solution.

## Data Logger Integration

- Can record temperature (°C), voltage (V), pressure (mPa), or force (kg).
- Recorded real-time data can be used as judgment criterion for cut-off or temperature protection measures.

## System Protection and Abnormality Detection

- Test recipes include various built-in protections; the protection mechanism monitoring these has a response speed of 1ms when triggered. An optional external voltage/temperature meter relay can be added to provide reliable dual-layer protection.
- Real-time abnormality detection allows each individual unit to automatically detect abnormalities based on independent logic. When the system is interrupted, the test can be continued after the exception is cleared without data loss.

## Chamber Integration and Peripheral Safety Engineering

- The Battery LEx software provides built-in chamber setting control and control steps for temperature, humidity, timeout, and over-temperature protections while indicating temperature control time, delay time, and standby temperature.
- To ensure consistency in test conditions, the grouping management structure allows all testing channels in the same chamber to enter the temperature control phase at the same time.
- The built-in DI/DO functionality can be connected to a smoke/gas detector, fire extinguisher, and alarms for over-temperature, over-voltage, and open door. The system performs different levels of handling according to the degree of damage, including stopping the test or powering off. Alarm data can be sent remotely via e-mail.

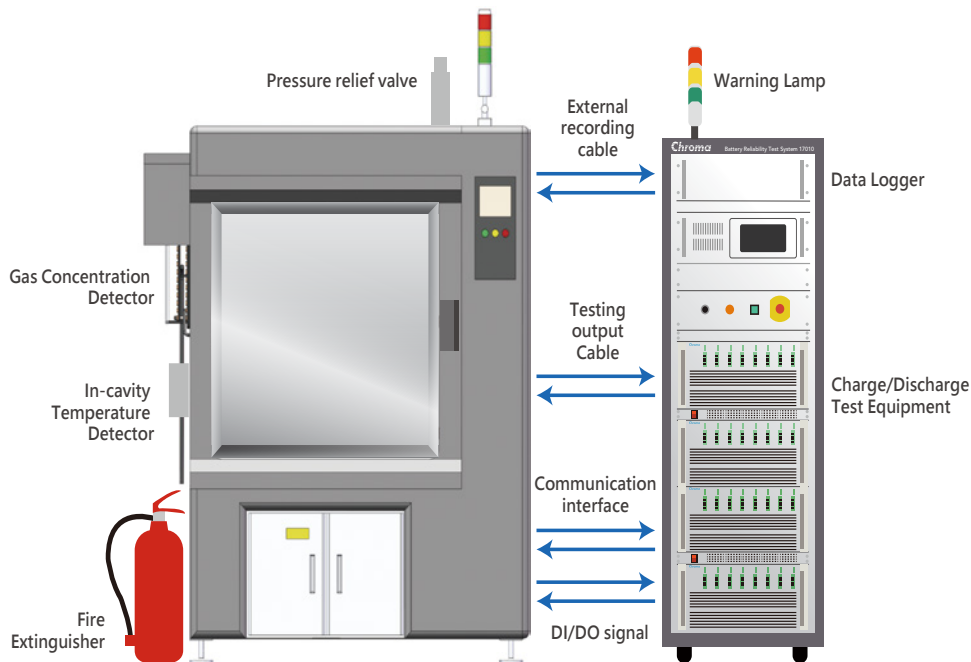

## Battery LEx Software

Battery Lab Expert (Battery LEx) is a comprehensive test software platform specifically developed for the Chroma 17010. It offers three key features and a rich set of tools for a variety of applications.

- Group testing: each group can control up to 96 channels and execute up to 50,000 steps
- Variable editing: use data from the external data logger for flexible programming and complex applications
- Chamber integration: real-time monitoring of chamber status and protection mechanisms through DI/DO expansion.

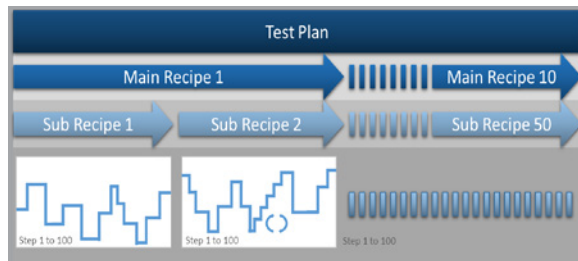

## Project Browser

- Streamlined management: Easily create and organize up to 500 test plans tailored to specific DUT types or test requirements.
- Intuitive display and real-time editing: Effortlessly browse, inspect, and adjust test plans, DUT specifications, waveform simulation data, and recipe content. Modify parameters on the fly and save them instantly for maximum efficiency.
- DUT database: Establish a central repository for all your DUT specifications, allowing you to quickly map parameters during recipe editing. Use recipe sharing for efficient testing across different projects.
- Operating simulation: Import data points directly from xlsx files to simulate operating conditions. Define time intervals (both equal and custom), output multiplier, and data ranges to create highly realistic test scenarios.

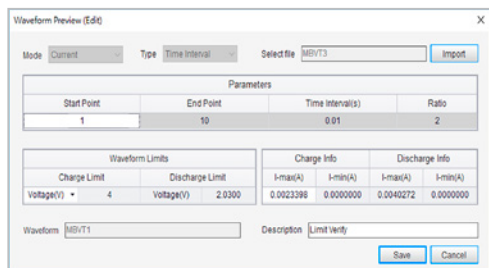

Waveform Simulation Database

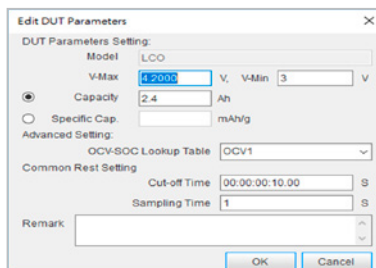

DUT Database

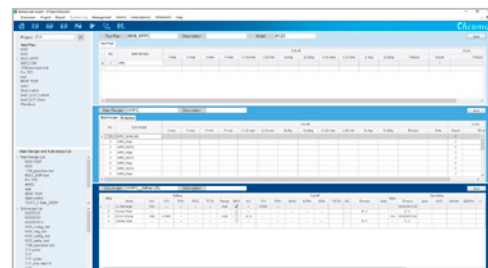

Project Browser

## Recipe Editor

- Layered structure: Craft intricate test plans with a hierarchical structure including up to 50,000 steps (SR -> MR -> TP).
- Easy creation: Design new recipes from scratch to address a wide range of test applications.
- Quick editing: Combine existing recipes to rapidly build comprehensive test plans.
- Special Settings: Utilize special settings for C-rate, OCV-SOC, Q%,  $\pm V$ , and variables to create highly customized recipes.
- Variable Settings and Cutoff Conditions: Define up to 20 variables, including 2 variables that can be leveraged across sub-recipes. The 1-100ms transient capture function meticulously records transient changes at the start/end of each step, then defines them as variables for secondary calculation.

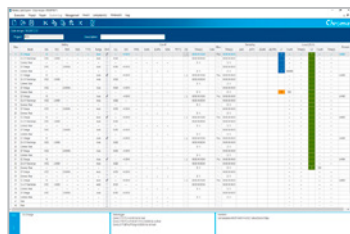

Sub-Recipe/Main Recipe/Test Plan Editor

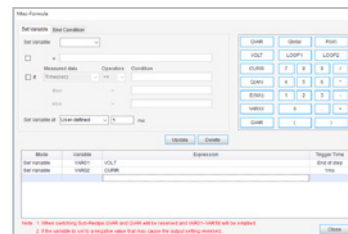
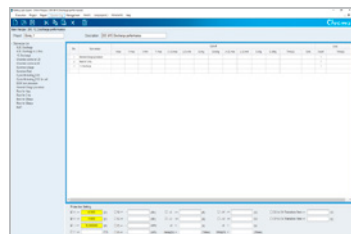

Variable Definition and Transient Capture

## Recipe Executor

- Multi-channel group management
- Multi-group start
- Various control options: Start, pause, resume, stop, reserved pause, specified start, skip to next step, pause and skip to next step, recipe preview
- Real-time test status: real-time display of test data for single channel and entire groups
- Supports dynamic paralleling for more demanding test requirements

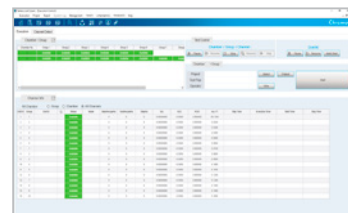

Recipe Executor

## Real-time Visualization

- Real-time data plotting: Plots data in real-time based on the set sampling time, with up to 36,000 data points displayed on a single screen.
- Multi-chart monitoring: View up to 4 independent graphs simultaneously, allowing for comparison of up to 2 test channels per graph.
- Graph capture: Use the time freeze function to capture and save test curves.
- Multi-axis analysis: Provides dual-Y-axis data display for more comprehensive analysis.



Real-time Chart Display

## Test Report

- Automatic Export: automatically exports to user-specified path based on defined export mode and filename
- Export modes: choose between manual export or automatic export based on either sub-recipes or time settings.
- Adjustable data precision up to 9 decimal places.
- Report types: generate channel-level or step-level reports.
- Customization: Freely adjust report items and column orders to tailor the report to your exact needs.

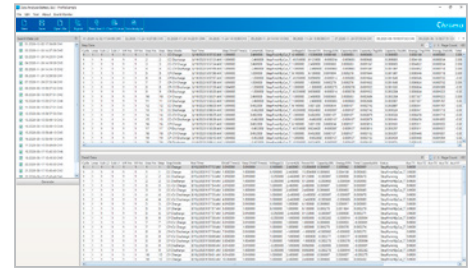

Test Report Preview

## Chamber Control and System DI/DO Signal Control

- Three control modes: chamber control steps, real-time remote control, maintenance mode
- Delay function: set a rest time after reaching the set temperature to ensure consistency between the temperatures of the chamber and the DUTs
- Cycle temperature setting: paired with a data logger, the system can adjust the chamber temperature based on the actual DUT temperature to accurately ensure temperature consistency.
- End-of-test setting modes: includes end temperature control, adjust to the specified temperature, and maintain temperature.
- Dual protection control: over-temperature protection, temperature control timeout protection
- External device control: provides three-color light signal control and relay signal control.
- Synchronized temperature control: automatic sync. mechanism ensures that the chamber temperature control starts only when all channels reach the "temperature control step", ensuring test consistency
- Temperature control inheritance: automatically transfer chamber control to another group upon completion of the main group's test.

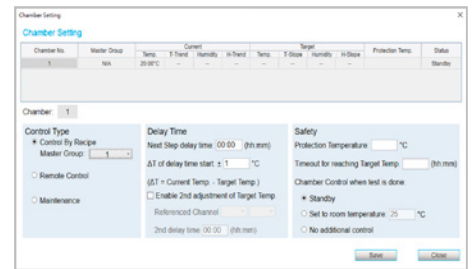

Chamber Control Settings

## Management

- Account and permission management: establish multiple user accounts with passwords and assign corresponding editing permissions.
- Alert notifications: set up email alerts for warning messages.
- Recipe transfer: import/export/move recipes and test plans
- Data management: administrators can set automatic or manual deletion of system data
- Forced global protection: set mandatory protection items for recipes to prevent human error and enhance test safety.

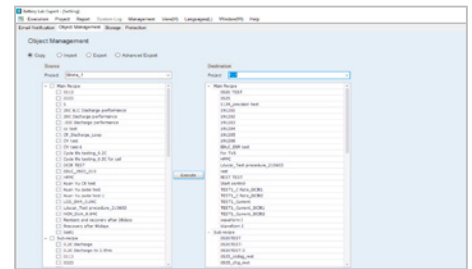

Test Plan Import/Export

## Real-Time Data Filtering and Chart Generation

- Data Query: Quickly filter large volumes of test data using custom conditions to accelerate analysis workflows.
- Chart Drawing: Flexible chart and table visualization with various plot configuration options to meet diverse testing and presentation needs.
- Graph Template Function: Display default charts to reduce manual operations and speed up analysis.
- Data Analysis: Rapidly identify abnormal data, enabling decision-makers to respond to issues in real time.

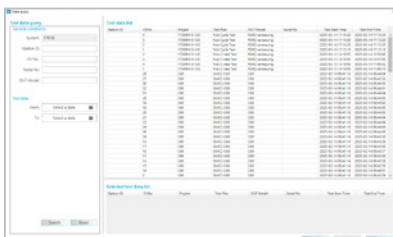

Data query

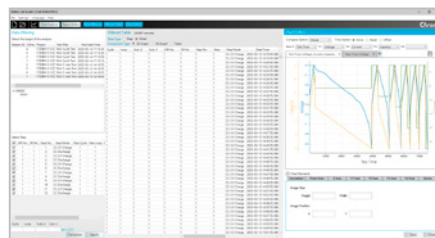

Data filtering and charting

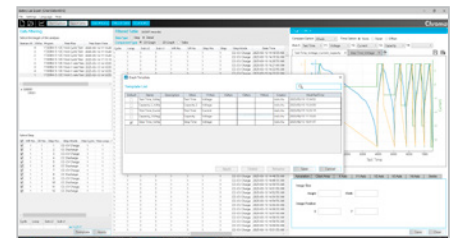

Graph Template

## Data Integration and Chart Management

- Automated Multi-Channel Operation: Apply charts to multiple selected channels simultaneously to reduce repetitive tasks.
- Flexible Drawing Modes: Generate separate charts or merge data into a single chart to suit different application scenarios.
- Accurate Table Configuration: Various layout options are available for clearer data output.
- Smart Parameter Matching: Automatically checks data consistency to ensure accurate merging.
- Standardized Naming Format: Automatically appends labels to merged charts to enhance traceability.
- Flexible Data Arrangement: Supports both vertical and horizontal layouts to improve readability.

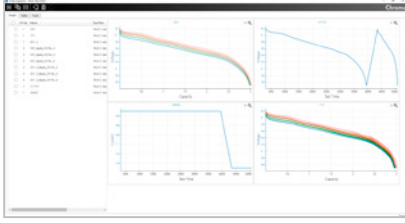
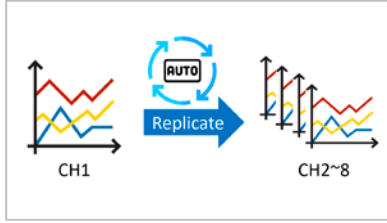
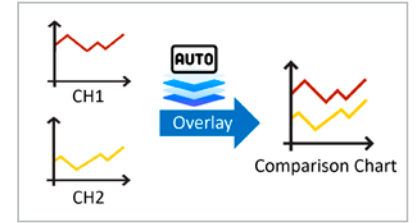

Chart Explorer



Replicate Function



Overlay Function

## Report Templates and Export

- Custom Report Template Function: Save frequently used formats to speed up report generation.
- Word-Processor-Like Interface: Create and export reports without relying on Microsoft Excel.
- Quick Insertion of Charts and Tables: Generate well-structured battery test reports with embedded visuals and data tables.

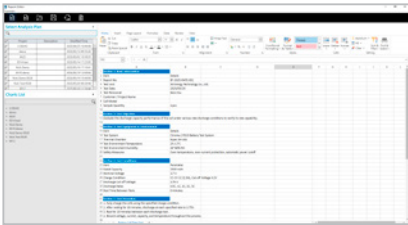

Report Editor

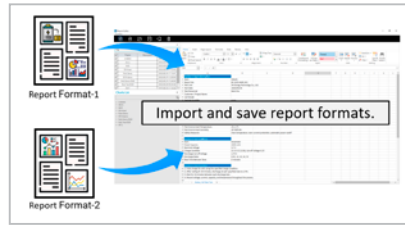

Report Layout

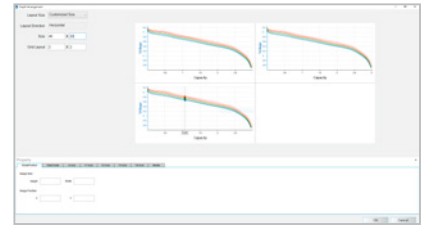

Graph Arrangement

## Lithium Battery Test Applications

### Ripple Current Superposition Applications

■ Verifying the efficiency of lithium-ion battery heating with AC current at temperatures below 0°C (32°F), the conductivity of the electrolyte significantly decreases while the internal resistance increases. This greatly reduces the battery's power capability, which in turn leads to decreased charging efficiency. One way to restore this efficiency is to pre-heat the battery directly with AC current. When selecting the frequency domain of the AC current, it is recommended to prioritize frequencies that do not induce electrochemical reactions in the battery.

■ Evaluating the impact of ripple on lithium-ion battery degradation Ripple mainly originates from inverters in electric vehicles. When the ripple frequency exceeds the frequency range detectable by the battery management system (BMS), and the ripple voltage exceeds the battery's upper voltage limit (e.g., when the ripple frequency is a multiple of the voltage detection frequency of the BMS), it may accelerate battery degradation. This is especially the case under conditions where the internal resistance of the battery cell increases by several factors at low temperatures.

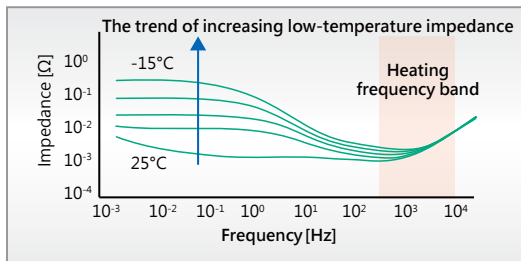

Application of Ripple Current Superposition

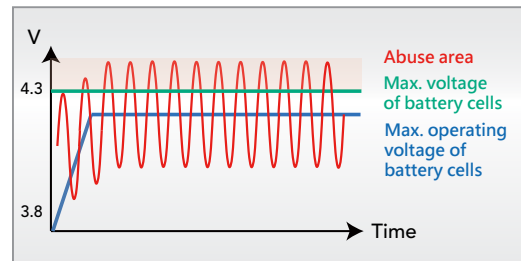

Evaluating the Impact of Ripple on Lithium-ion Battery Degradation

### Coulombic Efficiency (CE)

CE is calculated by fully charging and discharging the battery and then measuring the ratio of the total charge put into the battery. The Chroma 17010's best-in-class precision and stability allow you to easily identify batteries with superior characteristics. Through accurate CE testing, battery life can be estimated using fewer cycles, saving time and resources in the evaluation process.

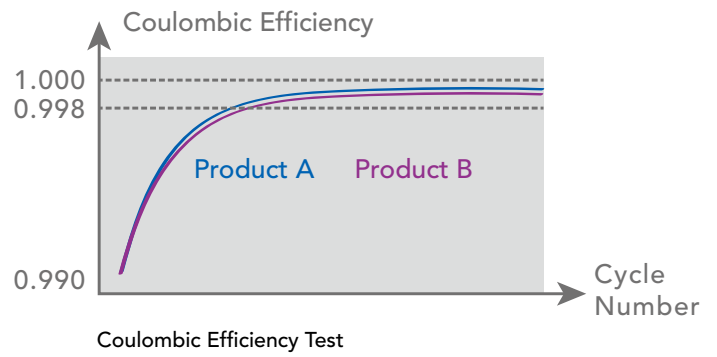

### Differential Voltage (dV/dQ)

The key to plotting the dV/dQ curve is to charge and discharge the battery with a small current (<math><C/20</math>) in order to eliminate the effect of polarization on the test result. The exceptionally low noise of the Chroma 17010 allows you to draw high-definition dV/dQ vs. Q curves, enabling you to view and mark each characteristic peak in detail. The ageing test allows you to analyze the battery's aging system based on the deviation and height of each characteristic peak.

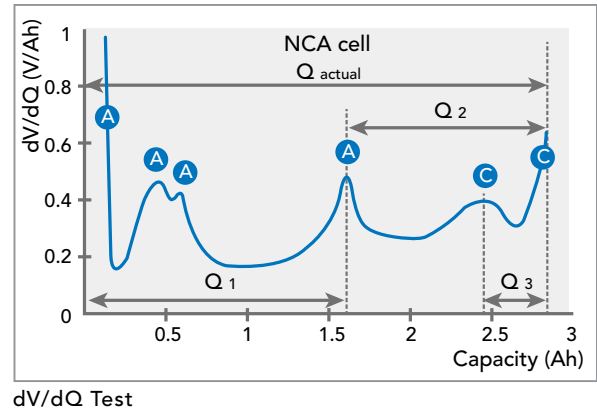

### One-Stop Electrochemical Impedance Spectroscopy (EIS) Testing Solution

The optional EIS measurement function can be integrated into a one-stop testing system, enabling flexible programming for both DC cycling tests and impedance analysis. This significantly enhances experimental efficiency and data consistency. The system architecture allows for testing without transferring the battery, minimizing contact variation and temperature fluctuations—further ensuring data consistency and repeatability. It is ideal for a wide range of applications, including battery performance evaluation, model selection, life prediction, degradation analysis, and BMS modeling.

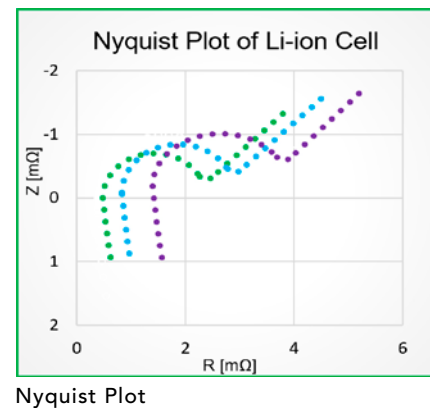

### Battery Cycle Life

Cycle life is one of the most important test items for batteries. Based on experimental objectives, this test subjects the battery through repeated charge and discharge conditions until the capacity falls to 80%, and then calculates the number of cycles. The cycle life test can be used to evaluate battery performance or define proper

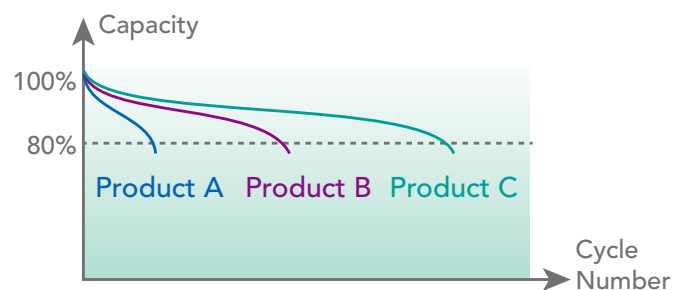

## Direct Current Internal Resistance (DCIR)

The internal resistance of a battery is related to the charge/discharge rate it can withstand. A higher internal resistance results in lower efficiency, increased heat generation, and accelerated aging. The traditional method of measuring AC internal resistance (ACIR) using a 1kHz LCR Meter can evaluate the battery's ohmic resistance ( $R_o$ ) affecting the instantaneous power output, but it cannot assess the polarization resistance ( $R_p$ ) produced during electrochemical reactions. In contrast, DCIR measurement includes ACIR while also more closely reflecting actual polarization effects in automotive battery applications involving continuous current. The Chroma 17010 has two programmable DCIR test modes, and – with the variable calculation function-can automatically obtain test results that meet the IEC 61960 standard.

■ DCIR (1) is based on the voltage difference caused by one current change

■ DCIR (2) is based on the voltage difference caused by the change between two currents

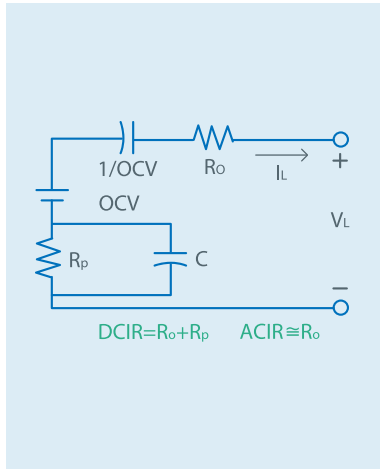

Li-ion battery Equivalent Circuit Model

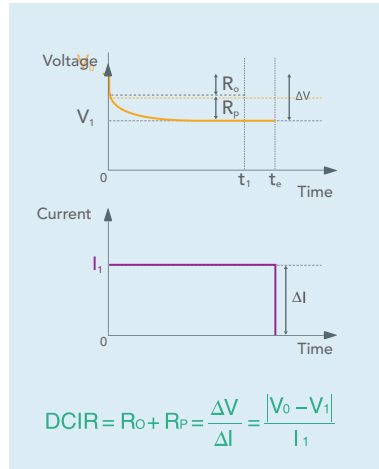

DCIR Test (1)

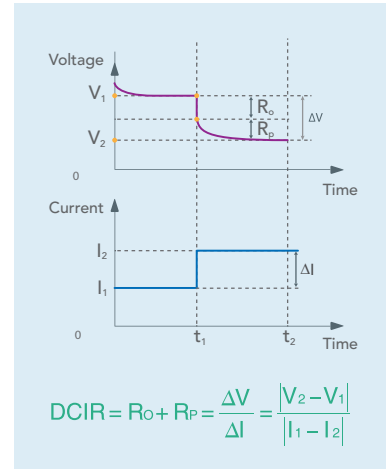

DCIR Test (2)

## Hybrid Pulse Power Characteristic (HPPC)

The Chroma 17010 features a flexible editing program that can compile HPPC test steps, as defined by the U.S. Council for Automotive Research (USCAR) for evaluation of EV battery performance. The purpose is to obtain the open circuit voltage, ohmic resistance ( $R_o$ ), and polarization resistance ( $R_p$ ) of a specific depth of discharge within the battery's operating voltage range using the specified test methods. It establishes a functional relationship between the depth of discharge and the charge/discharge peak power, serving as an indicator for evaluating the battery cell's aging and output power capacity.

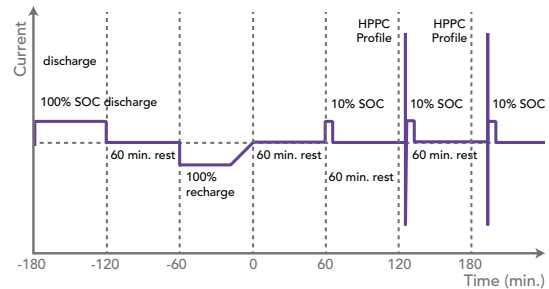

(HPPC) HPPC Test

## LIC End-of-Line and Durability Testing

With the rapid expansion of AI applications, the floating-point operations per second (FLOPS) of large language models (LLMs) are growing exponentially. The increasing power demand of high-density integrated AI GPUs used for training and inference presents a major challenge for data centers: how to reliably deliver peak power without interrupting GPU operation. To address this issue, capacitor energy storage systems (CESS) based on lithium-ion capacitors (LICs) are now commonly adopted as a backup power solution.

■ IEC 62813 End-of-Line Testing Solution:

The Chroma 17010/17010H systems are equipped with test sequences compliant with IEC 62813, allowing users to perform capacitance and DC internal resistance (DCIR) tests. This facilitates accurate classification and evaluation of DUTs.

■ Support for LIC Durability Testing:

To ensure LICs used in CESS can provide stable high-power output over extended periods, performance degradation testing is required during the selection process. The Chroma 17010 and 17010H systems support cycle life and durability testing with low output noise and high measurement accuracy-delivering high-quality data for reliable LIC characterization.

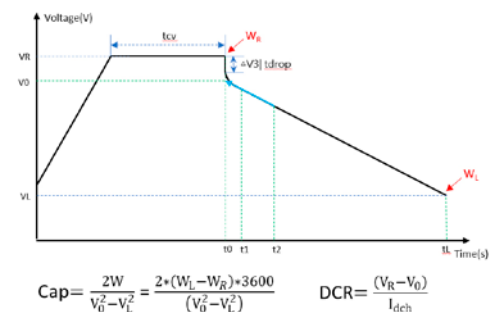

## Lithium Battery Test Applications

The Chroma 17010 Battery Reliability Test System meets the verification requirements of most international regulations in charge/discharge testing.

Type	Regulation	Standard Number	Test Items
IEC	Secondary lithium-ion cells for the propulsion of electric road vehicles -Part 1: Performance testing	IEC 62660-1 2010	7.1 General charge conditions 7.2 Capacity 7.3 SOC adjustment 7.4.1 Power test method 7.5.1 Energy test method 7.6 Storage test 7.7 Cycle life test 7.8 Common tests
	Secondary cells and batteries containing alkaline or other non-acid electrolytes -Secondary lithium cells and batteries for portable applications	IEC 61960 2011	7.3 Discharge performance 7.4 Charge (Capacity) retention and recovery 7.5 Charge (Capacity) recovery after long term storage 7.6 Endurance in cycle
	Fixed electric double-layer capacitors for use in electronic equipment-Part 1: Generic specification	IEC 62391-1 2006	4.5 Discharge performance 4.6.2 Charge (Capacity) retention and recovery 4.7 Leakage current 4.8 Self discharge
	Lithium ion capacitors for use in electric and electronic equipment-Test methods for electrical characteristics	IEC 62813 2015	4.2.1 Capacitance, discharge accumulated electric energy, and internal resistance
GB/T	Cycle life requirements and test methods for traction battery of electric vehicle	GB/T 31484 2015	6.1 Test conditions 6.2 Capacity and energy under room temperature (initial capacity and energy) 6.3 Power under room temperature (initial power) 6.4 Standard cycle life 6.5 Operating-condition cycle life
	Electrical performance requirements and test methods for traction battery of electric vehicle	GB/T 31486 2015	6.2.4 Secondary cell charging 6.2.5 Discharge capacity under room temperature (initial capacity)
	General specification of lithium-ion cells and batteries for mobile phone	GB/T 18287 2013	5.3.2.1 Charging methods 5.3.2.2 0.2 ItA discharge 5.3.2.3 Rated discharge 5.3.2.4 High temperature discharge 5.3.2.5 Low temperature discharge 5.3.2.6 Charge retention capability and recovery capacity 5.3.2.7 Storage performance 5.3.2.8 Cycle life 5.3.3.2 Steady damp-heat
USABC	Battery Test Manual for 48 Volt Mild Hybrid Electric Vehicles	Rev.0 2017	3.2 Static Capacity Test 3.3 Constant Power Discharge and Charge Tests 3.4 Hybrid Pulse Power Characterization Test 3.5 Standard Self Discharge Test 3.6 Cold Cranking Test 3.7 Thermal Performance Test 3.8 Energy Efficiency Test 3.9 Operating Set Point Stability Test 3.10 Cycle Life Test 3.11 Calendar Life Test
	Battery Test Manual for 12 V Start/Stop Vehicles	Rev.2 2018	3.2 Static Capacity Test 3.3 Constant Power Discharge and Charge Tests 3.4 Hybrid Pulse Power Characterization Test 3.5 Standard Self Discharge Test 3.6 Cold Cranking Test 3.7 Thermal Performance Test 3.8 Energy Efficiency Test 3.9 Operating Set Point Stability Test 3.10 Cycle Life Test 3.11 Calendar Life Test
	Battery Test Manual for Electric Vehicle	Rev.3.1 2020	3.2 Static Capacity Test 3.3 High Rate Charge 3.4 Hybrid Pulse Power Characterization Test 3.5 Peak Power Test 3.6 Self-Discharge Test 3.7 Thermal Performance Test 3.8 Life Testing 3.9 Cycle Life Dynamic Stress Tests 3.10 Calendar Life Test
	Battery Test Manual for Plug In Hybrid Vehicle	Rev.3	3.2 Static Capacity Test 3.3 Constant Power Discharge Tests 3.4 Hybrid Pulse Power Characterization Test 3.5 Self-Discharge Test 3.6 Cold Cranking Test 3.7 Thermal Performance Test 3.8 Energy Efficiency Test 3.9 Life Testing 3.10 Charge-Sustaining Cycle Life Tests 3.11 Charge-Depleting Cycle Life Test Profile 3.12 Calendar Cycle Life Test

## Battery Cell Testing Data Loggers

The Multi-Channel Data Loggers Chroma A172013 (Voltage), A172014 (Temperature-Thermocouple Type), and A172015 (Temperature-Resistance Type) can serve as auxiliary channels for the 17010 system, providing real-time monitoring of DUT data during charge and discharge tests. This data can then be integrated into the test report via the Battery LEx software, where you can also set upper limit protections to ensure test safety.

- Each channel adopts independent 24-bit ADC sampling
- Equipped with cold junction compensation function
- Can be used as a standalone unit or connected to voltage or temperature modules, expandable up to 128 channels

Multi-Channel Voltage Data Logger A172013						
Channels	16					
Number of Modules Connected <sup>*1</sup>	Up to 8 pcs					
Interface	Ethernet					
Measurement Range	±10V	±5V	±1V	±0.5V	±100mV	±20mV
Accuracy <sup>*2</sup>	±0.015% of F.S.					
Resolution	0.3mV	150µV	30µV	150µV	3µV	0.6µV
Max. Voltage to Ground	±300V					
Max. Voltage between Channels	±250Vdc					
Wire Connection	M3 screw					
Sampling Time <sup>*3</sup>	10ms					

A172015 Multi-Channel Temperature Data Logger (RTD)		
Channels	16	
Number of Modules Connected	Up to 8 pcs	
Interface	Ethernet	
Measurement Range	Range	Measure Range
	100°C	-100°C to 100°C
	500°C	-200°C to 500°C
	2000°C	-200°C to 800°C
Accuracy (23±5°C)	±0.05% f.s. ±0.5°C	
Resolution	0.04°C	
Terminal	European Terminal Block (PT100)	
Sampling Time <sup>*3</sup>	10ms	

Note\*1: A172013, A172014, and A172015 modules can be integrated and used simultaneously.

Note\*2: The accuracy specification does not include errors caused by the testing cables, under the condition of 100ms sampling and 23±5°C.

Note\*3: The sampling time is for the single unit specification and does not include data integration and transmission.

## Ripple Current Superposition Test System

Chroma's Ripple Current Superposition Test System consists of a programmable high-frequency AC tester, an AC/DC decoupling module, and a DC charge/discharge tester. The independent AC and DC loops can be applied to various charge and discharge modes, with minimal impact on the cut-off judgment of DC charge and discharge tests, aiding in cycle life comparison.

11805-20-10 & A170105 Specifications		
Max. Integrated Channels in the System	1-4ch	
Communication Interface	RS485, DI/DO	
Output	Frequency	100Hz-20kHz
	Waveform	Sine Wave
	Max. AC Amplitude	75 Ap-p
	Channels in parallel	2ch (150Ap-p)
Oscilloscope	option	
AC Output Cable	2-meter low-inductance output	

## Integrated One-Stop EIS Testing Device

The Chroma Electrochemical Impedance Spectroscopy (EIS) Testing System integrates the Hioki customized BT4560-50 Battery Impedance Tester and SW1002 Scanning Module Rack, enabling users to perform DC tests and impedance analysis simultaneously. This integration helps accelerate battery performance evaluation.

EIS Testing Device Specification	
EIS Frequency Range	10kHz-10mHz
Impedance Measurement Accuracy	R : ± (0.4%  R  + 0.52%  X ) ± 4.5 µΩ
Impedance Measurement Resolution	X : ± (0.4%  X  + 0.52%  R ) ± 4.5 µΩ
	0.1 µΩ



Multi-Channel Temperature Data Logger A172014 (Thermocouple Type)		
Channels	16	
Number of Modules Connected <sup>*1</sup>	Up to 8 pcs	
Interface	Ethernet	
Measurement Range	Range	Measure Range
	K 100°C	-100°C to 100°C
	K 500°C	-200°C to 500°C
	K 2000°C	-200°C to 1350°C
	J 100°C	-100°C to 100°C
	J 500°C	-200°C to 500°C
	J 2000°C	-200°C to 1200°C
	T 100°C	-100°C to 100°C
T 500°C	-200°C to 400°C	
T 2000°C	-200°C to 400°C	
Accuracy <sup>*2</sup>	±0.05% of F.S. ±1°C	
Resolution	0.1°C	
Temperature Transducer	J, K, T type Thermocouple	
Wire Connection	M3 screw	
Sampling Time <sup>*3</sup>	10ms	

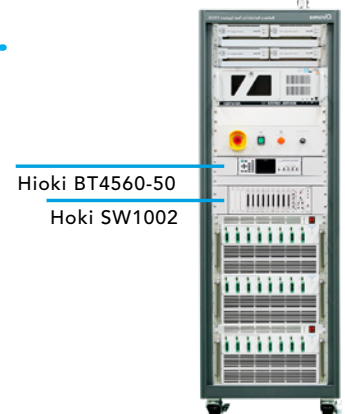
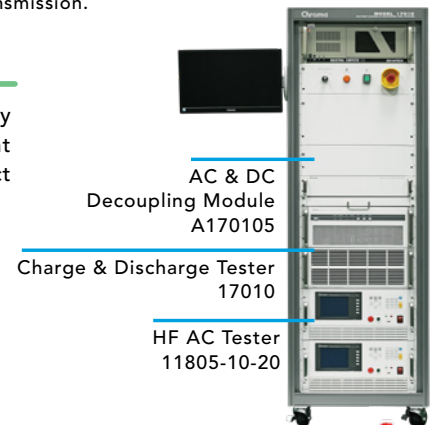

## Battery Cell Test System Auto Calibrator

The Chroma A170103 is an automated calibration and verification system equipped with various high-precision standard components. It features programmable control for multi-channel calibration tasks and is suitable for products in the Chroma 17010 series with currents up to 150A. This system ensures the equipment maintains high accuracy and traceability, forming an integral part of Chroma's high-precision test solutions.

- Consistent and standardized inspection: scientific approach minimizes human error and test variability
- Efficient calibration and verification: reduces workforce requirements and saves costs
- Automated report generation: ensures traceability and easy management of maintenance records

Specifications	
Voltage	0-10V
Current	1mA/10mA/100mA/1A/6A/30A/150A (7 ranges)
Channels	16CHs/time
Input	Single-phase AC 100V-120V/Single-phase AC 200V-240V ± 10% (manual switch)
Dimensions (W x D x H) (mm)	600 x 900 x 1100
Weight (Kg)	<150
Equipment	
Standard	A170103, A820001 S/W, IPC & Windows 10 & Office, RS-485 card, 7230 I/O card
Option	30ppm digital DMM, Monitor, Keyboard & mouse



## Environmental and Rack Specifications

Environmental and External Specifications		
Operating temperature	0°C-40°C	
Operating humidity	<90 RH%	
Input	3Φ 200-220Vac ± 10% V <sub>LL</sub> 3Φ 380-400Vac ± 10% V <sub>LL</sub> Frequency 47-63Hz	
Dimensions (W x D x H) (mm)	25U	600 x 1100 x 1340
	36U	600 x 1100 x 1830
	41U	600 x 1100 x 2060
Weight (Kg)	25U	<160
	36U	<370
	41U	<510

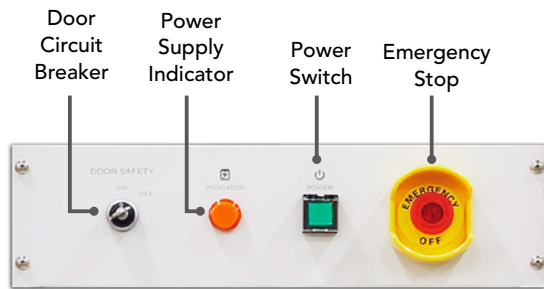

Emergency Panel



25U Rack



36U Rack



41U Rack

## Ordering Information

System	17010						
Model	Current Range	Voltage Range	Super Mode	0V Discharge	Regenerative Mode	Channels	Rack
17216-6-6	6A/1.2A/0.6A/1mA	0-6V	--	--	--	16/32/48/64/80/96	19" (25U) (36U) (41U)
17216-6-12	12A/2.4A/1.2A/1mA	0-6V	--	--	--	16/32/48/64/80/96	
17216M-10-6	6A/0.2A/6mA/0.2mA	0-10V/0-5V/±5V	--	Yes	--	16/32/48/64/80/96	
17216M-6-12	12A/3A/1A/0.1A	0-6V	--	Yes	--	16/32/48/64/80/96	
17208M-5-12C	12A/4A/0.4A/0.04A	0-5V	--	Yes	--	8/16/32/40/48/56/64	
17208M-6-30	30A/10A/0.1A/1mA	0-6V	--	Yes	--	8/16/24/32/40/48/56/64	
17208M-6-60	60A/15A/5A/0.5A	0-6V	--	Yes	--	8/16/24/32/40/48/56/64	
17212M-6-100S	100A/50A/25A	0-6V	Yes	--	Yes	12/24/36/48	

Option		
Model	Items	Channels
A172013	Multi-Channel Voltage Data Logger	16/32/48/64/80/96/112/128
A172014	Multi-Channel Temperature Data Logger (Thermocouple Type)	16/32/48/64/80/96/112/128
A172015	Multi-Channel Temperature Data Logger (RTD type_PT100)	16/32/48/64/80/96/112/128
A170103	Battery Cell Test System Auto Calibrator	16
A170105	AC & DC Decoupling Module	2
11805-20-10	Programmable HF AC Tester	1

\* Continued on next page

# Specifications

Model		17208M-5-12C			
Voltage					
Accuracy		± 0.01% of F.S.			
Precision <sup>1</sup>		±0.001% of F.S.			
Range		0V-5V			
Resolution	Setting	10µV			
	Measurement	1µV			
Current					
Accuracy		± 0.01% of F.S.			
Precision <sup>1</sup>		±0.001% of F.S.			
Range		40mA	400mA	4A	12A
Resolution	Setting	100nA	1µA	10µA	100µA
	Measurement	10nA	100nA	1µA	10µA
Power					
Accuracy		± 0.022% F.S.			
Range		0.2W	2W	20W	60W
Resolution	Setting	0.5µW	5µW	50µW	150µW
	Measurement	50nW	0.5µW	5µW	15µW
Minimum Data Sampling Time		10ms			
Current Rise Time (+10%~+90%)		<1ms			

Model		17216-6-6				17216-6-12			
Voltage									
Accuracy		±0.015% of F.S.							
Range		Charge 0V-6V ; Discharge 1.5V-6V							
Resolution	Setting	1mV							
	Measurement	0.1mV							
Current									
Accuracy		6A: ±0.02% of F.S. Others: ±0.04% of F.S.				12A: ±0.02% of F.S. Others: ±0.04% of F.S.			
Range		1mA	0.6A	1.2A	6A	1mA	1.2A	2.4A	12A
Resolution	Setting	1µA	1mA	1mA	1mA	1µA	1mA	1mA	10mA
	Measurement	0.1µA	0.1mA	0.1mA	0.2mA	0.1µA	0.1mA	0.1mA	1mA
Power									
Accuracy		36W: ±0.035% of F.S. Others: ±0.055% of F.S.				72W: ±0.035% of F.S. Others: ±0.055% of F.S.			
Range		6mW	3.6W	7.2W	36W	6mW	7.2W	14.4W	72W
Resolution	Setting	1µW	1mW	1mW	10mW	1µW	1mW	10mW	10mW
	Measurement	0.1µW	0.1mW	0.1mW	1mW	0.1µW	0.1mW	1mW	1mW
Minimum Data Sampling Time		10ms							
Current Rise Time (+10%~+90%)		500µs				500µs			

Model		17216M-10-6				17216M-6-12			
Voltage									
Accuracy		± 0.015% of F.S.							
Range		0V-10V, 0V-5V or -5V-5V							
Resolution	Setting	1mV							
	Measurement	0.1mV							
Current									
Accuracy		±0.02% of F.S.							
Range		200µA	6mA	200mA	6A	100mA	1A	3A	12A
Resolution	Setting	0.1µA	1µA	0.1mA	1mA	0.1mA	1mA	1mA	10mA
	Measurement	0.01µA	0.2µA	0.01mA	0.2mA	0.01mA	0.1mA	0.1mA	1mA
Power									
Accuracy		±0.035% of F.S.							
Range		2mW	60mW	2W	60W	600mW	6W	18W	72W
Resolution	Setting	1µW	10µW	1mW	10mW	0.1mW	1mW	10mW	10mW
	Measurement	0.1µW	2µW	0.1mW	2mW	10µW	0.1mW	1mW	1mW
Minimum Data Sampling Time		10ms							
Current Rise Time (+10%~+90%)		100µs				250µs			

Model		17208M-6-30				17208M-6-60				17212M-6-100S			
Voltage													
Accuracy		±0.015% of F.S.								±0.02% of F.S.			
Range		0V-6V								Charge 0V-6V ; Discharge 1.5V-6V			
Resolution	Setting	1mV								1mV			
	Measurement	0.1mV								0.1mV			
Current													
Accuracy		±0.02% of F.S.				±0.02% of F.S.				±0.05% of F.S. <sup>2</sup>			
Range		1mA	100mA	10A	30A	500mA	5A	15A	60A	25A	50A	100A	120A(ST)
Resolution	Setting	1µA	0.1mA	10mA	10mA	0.1mA	1mA	10mA	10mA	1mA	5mA	10mA	10mA
	Measurement	0.1µA	0.01mA	1mA	1mA	0.01mA	0.1mA	1mA	1mA	0.1mA	0.5mA	1mA	1mA
Power													
Accuracy		±0.035% of F.S.								±0.07% of F.S. <sup>2</sup>			
Range		6mW	600mW	60W	180W	3W	30W	90W	360W	150W	300W	600W	720W
Resolution	Setting	1µW	0.1mW	10mW	10mW	1mW	10mW	10mW	100mW	10mW			
	Measurement	0.1µW	10µW	1mW	1mW	0.1mW	1mW	1mW	10mW	1mW			
Minimum Data Sampling Time		10ms											
Current Rise Time (+10%~+90%)		250µs				500µs				1ms			

Model		17208M-6-30				17208M-6-60				17212M-6-100S			
Voltage													
Accuracy		±0.015% of F.S.								±0.02% of F.S.			
Range		0V-6V								Charge 0V-6V ; Discharge 1.5V-6V			
Resolution	Setting	1mV								1mV			
	Measurement	0.1mV								0.1mV			
Current													
Accuracy		±0.02% of F.S.				±0.02% of F.S.				±0.05% of F.S. <sup>2</sup>			
Range		1mA	100mA	10A	30A	500mA	5A	15A	60A	25A	50A	100A	120A(ST)
Resolution	Setting	1µA	0.1mA	10mA	10mA	0.1mA	1mA	10mA	10mA	1mA	5mA	10mA	10mA
	Measurement	0.1µA	0.01mA	1mA	1mA	0.01mA	0.1mA	1mA	1mA	0.1mA	0.5mA	1mA	1mA
Power													
Accuracy		±0.035% of F.S.								±0.07% of F.S. <sup>2</sup>			
Range		6mW	600mW	60W	180W	3W	30W	90W	360W	150W	300W	600W	720W
Resolution	Setting	1µW	0.1mW	10mW	10mW	1mW	10mW	10mW	100mW	10mW			
	Measurement	0.1µW	10µW	1mW	1mW	0.1mW	1mW	1mW	10mW	1mW			
Minimum Data Sampling Time		10ms											
Current Rise Time (+10%~+90%)		250µs				500µs				1ms			

Model		17208M-6-30				17208M-6-60				17212M-6-100S			
Voltage													
Accuracy		±0.015% of F.S.								±0.02% of F.S.			
Range		0V-6V								Charge 0V-6V ; Discharge 1.5V-6V			
Resolution	Setting	1mV								1mV			
	Measurement	0.1mV								0.1mV			
Current													
Accuracy		±0.02% of F.S.				±0.02% of F.S.				±0.05% of F.S. <sup>2</sup>			
Range		1mA	100mA	10A	30A	500mA	5A	15A	60A	25A	50A	100A	120A(ST)
Resolution	Setting	1µA	0.1mA	10mA	10mA	0.1mA	1mA	10mA	10mA	1mA	5mA	10mA	10mA
	Measurement	0.1µA	0.01mA	1mA	1mA	0.01mA	0.1mA	1mA	1mA	0.1mA	0.5mA	1mA	1mA
Power													
Accuracy		±0.035% of F.S.								±0.07% of F.S. <sup>2</sup>			
Range		6mW	600mW	60W	180W	3W	30W	90W	360W	150W	300W	600W	720W
Resolution	Setting	1µW	0.1mW	10mW	10mW	1mW	10mW	10mW	100mW	10mW			
	Measurement	0.1µW	10µW	1mW	1mW	0.1mW	1mW	1mW	10mW	1mW			
Minimum Data Sampling Time		10ms											
Current Rise Time (+10%~+90%)		250µs				500µs				1ms			

Note\*1: Accuracy is specified under conditions of 100ms sampling and a temperature of 23±5°C.

Note\*2: Short-Term (ST) output capability provides up to 120% of constant current/constant power for a maximum of 30 seconds within a 60-second period. Current accuracy is ±0.1% of F.S., and power accuracy is ±0.12% of F.S.

Get more product & global distributor information in the Chroma ATE APP

\* All specifications are subject to change without notice.



iOS





Android

Keyword search in the APP

17010

HEADQUARTERS  
CHROMA ATE INC.  
88 Wenmao Rd.,  
Guishan Dist.,  
Taoyuan City  
333001, Taiwan  
T +886-3-327-9999  
F +886-3-327-8898  
www.chromaate.com  
info@chromaate.com

U.S.A.  
CHROMA ATE, INC. (U.S.A.)  
7 Chrysler, Irvine,  
CA 92618, U.S.A.  
T +1-949-421-0355  
F +1-949-421-0353  
Toll Free +1-800-478-2026  
www.chromaau.com  
info@chromaus.com

CHROMA SYSTEMS  
SOLUTIONS, INC.  
19772 Pauling,  
Foothill Ranch,  
CA 92610, U.S.A.  
T +1-949-600-6400  
F +1-949-600-6401  
www.chromausa.com  
sales@chromausa.com

EUROPE  
CHROMA ATE EUROPE B.V.  
Morsestraat 32, 6716 AH  
Ede, The Netherlands  
T +31-318-648282  
F +31-318-648288  
www.chromaau.com  
salesnl@chromaau.com

CHROMA GERMANY GMBH  
Südtiroler Str. 9, 86165,  
Augsburg, Germany  
T +49-821-790967-0  
F +49-821-790967-600  
www.chromaau.com  
salesde@chromaau.com

JAPAN  
CHROMA JAPAN  
CORP.  
888 Nippa-cho,  
Kouhoku-ku,  
Yokohama-shi,  
Kanagawa,  
223-0057 Japan  
T +81-45-542-1118  
F +81-45-542-1080  
www.chroma.co.jp  
info@chroma.co.jp

KOREA  
CHROMA ATE  
KOREA BRANCH  
312, Gold Tower,  
14-2, Pangyo-eok-ro  
192, Bundang-gu,  
Seongnam-si,  
Gyeonggi-do,  
13524, Korea  
T +82-31-781-1025  
F +82-31-8017-6614  
www.chroma.co.kr  
info@chromaate.com

CHINA  
CHROMA ELECTRONICS  
(SHENZHEN) CO., LTD.  
8F, No.4, Nanyou Tian  
An Industrial Estate,  
Shenzhen, China  
T +86-755-2664-4598  
www.chroma.com.cn  
info@chromaate.com

SOUTHEAST ASIA  
QUANTEL PTE LTD.  
(A company of Chroma Group)  
25 Kallang Avenue #05-02  
Singapore 339416  
T +65-6745-3200  
F +65-6745-9764  
www.quantel-global.com  
sales@quantel-global.com